

E0413-HD

Liquid End

* THESE COMPONENTS ARE LOCATED IN THE FLUID CYLINDER GROUP, ITEM ②
 ** THESE COMPONENTS ARE LOCATED IN THE ATTACHING GROUP, ITEM ③
 *** THESE COMPONENTS ARE LOCATED IN THE CYLINDER GROUP, ITEM ④

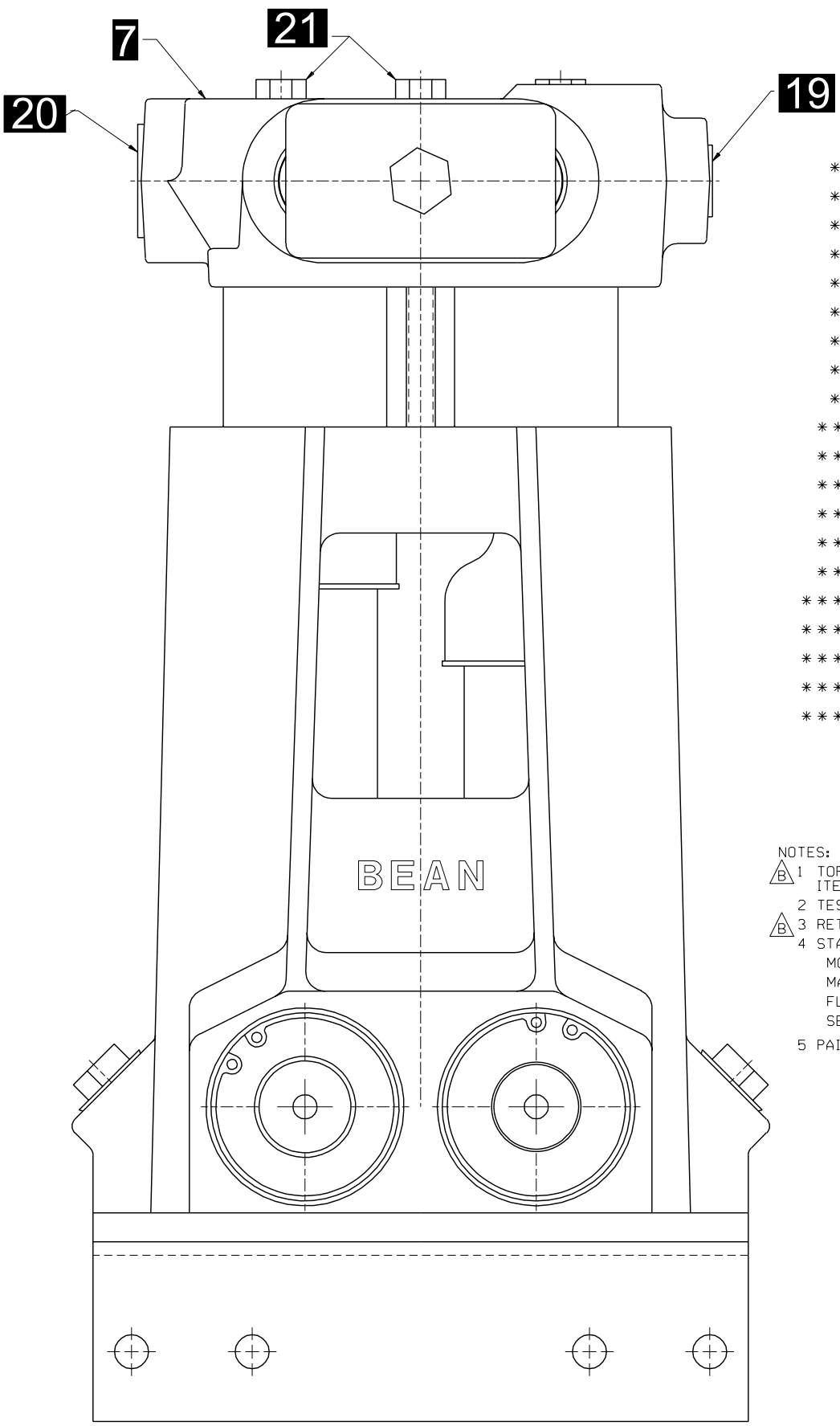
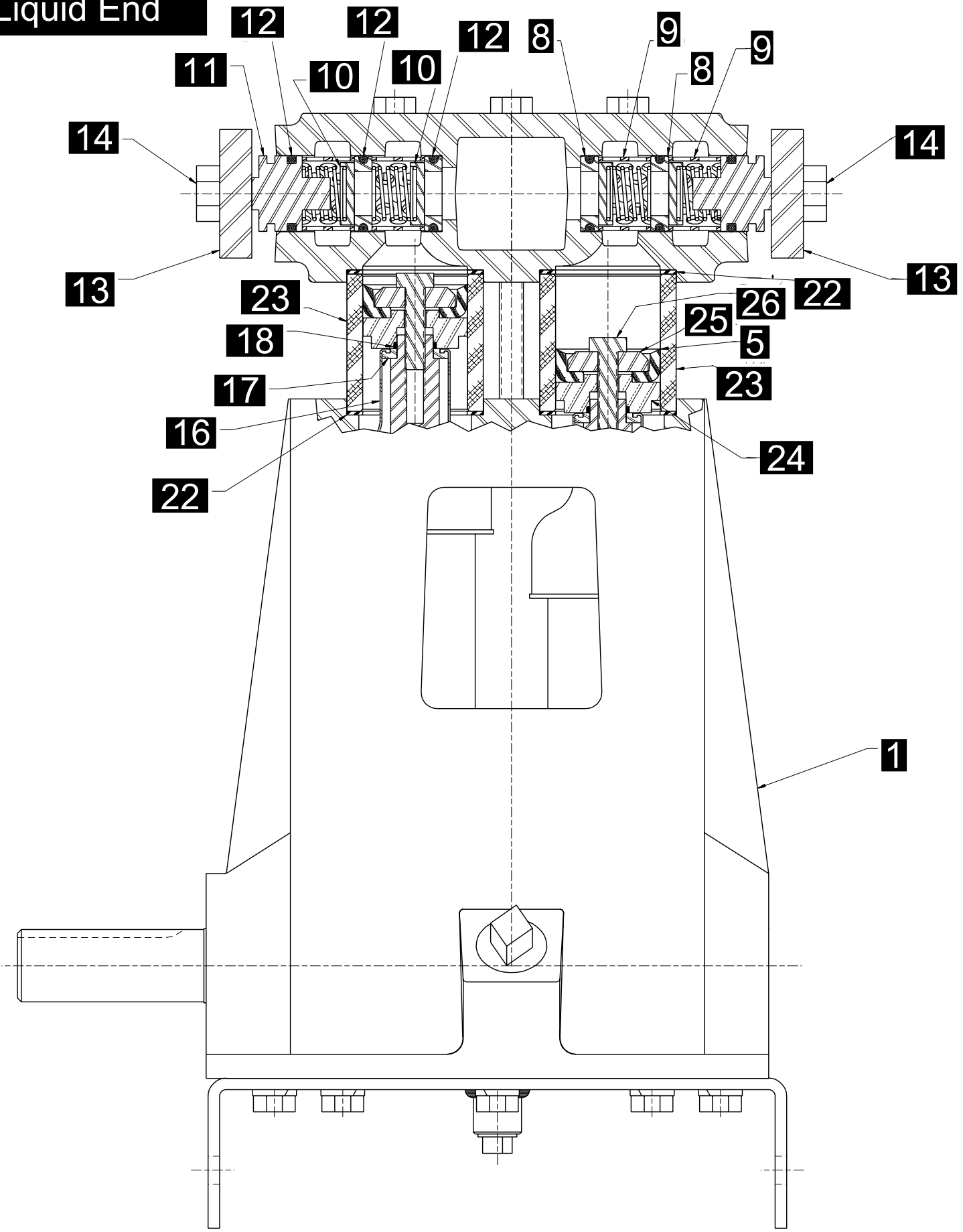

ITEM	NO. RECD	PART NO.	PART NAME
①	1	P510889	POWER END: HEAVY DUTY
②	1	5260309	FLUID CYLINDER GROUP:
③	1	5273638	ATTACHING GROUP:
④	2	5273629	CYLINDER GROUP:
⑤	4	5257807	CUP: 1 1/8" DIA, CARBOXILATED NITRILE FABRIC
⑥	1	5266225	LIT KIT:
* ⑦	1	5256139	FLUID CYLINDER: NITRIDED
* ⑧	8	5260142	VALVE SEAT: 450 SST
* ⑨	8	1219610	CAGE: 302 SST
* ⑩	8	5253499	DISC & SPRING ASSEMBLY: 450 SST
* ⑪	4	1219614	VALVE COVER:
* ⑫	12	1177394	O-RING: 1 3/16" OD X 1/8" NOM., BUNA-N
* ⑬	2	1255887	VALVE COVER CLAMP:
* ⑭	2	1100064	HEX HD CAP SCREW: 1/2-13 X 1 1/2" LG.
* ⑮	1	1109987	PLUG: 1/4" PIPE (NOT SHOWN)
** ⑯	4	1279148	UMBRELLA: BLACK
** ⑰	4	1269388	UMBRELLA WASHER:
** ⑱	4	1101339	O-RING: 1 1/16" OD X 1/16" NOM., BUNA-N
** ⑲	1	1177200	CAPLUG: INT. 12
** ⑳	1	1177202	CAPLUG: INT. 17S
** ㉑	4	1101262	HEX HD CAP SCREW: 3/8-16 X 5" LG.
*** ㉒	8	A91684	CYLINDER GASKET:
*** ㉓	4	1241364	CERAMIC CYLINDER:
*** ㉔	4	1282557	PACKING HOLDER:
*** ㉕	4	5257986	PACKING WASHER:
*** ㉖	4	1284516	HEX HD CAP SCREW: 5/16-18 X 1 1/2" LG.

NOTES:
 Ⓐ 1 TORQUE ITEM 21 TO 55 FT-LBS; ITEM 14 TO 35 FT-LBS
 ITEM 26 TO 10 FT-LBS
 2 TEST AT 500 RPM, 1500 PSI
 Ⓑ 3 RETORQUE ITEM 21 AFTER TEST
 4 STAMP NAMEPLATE WITH THE FOLLOWING DATA:
 MODEL NO. - E0413 HD PART NO. - P510904
 MAX RPM. - 700 POWER - 14.6 HP / 10.9 KW
 FLOW - 15 GPM/56 LPM MAX PRESSURE - 1500 PSI/10340 KPA
 SERIAL NO. -
 5 PAINT PER ENGR SPEC CP-20

B	REV NOTES	02/18/00	SJK	07-18-00	RELEASED FOR PRODUCTION	SCALE: NONE
A	NEW ISSUE	03-17-00	SJK	03-17-00	ECN	DATE
REV	WAS	ECN	BY	DATE	5004427	03-29-00

P510904

This drawing is the property of FMC Corporation and may not be used, reproduced, published, or disclosed to others without express authorization FMC Corp.

FMC FMC Corporation
 Fluid Control Division
 2825 W. Washington Box 1377
 Stephenville, Texas 76481

Unless Otherwise Specified:
 Remove all burrs & sharp corners .005 R.
 All diameters concentric unless .001 I.D.
 Angles ±1/2°
 .XX ±.015
 .XXX ±.005
 Finish 125 RMS
 All dimensions are in inches

PUMP ASSEMBLY
 E0413 HD, W/1 1/4" NPT X 3/4" NPT FLUID
 END, CARBOX. NITRILE CUPS, SST
 DISC VALVE ASSEMBLIES

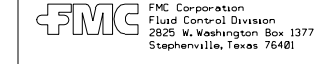

PUMP ASSEMBLY
 E0413 HD, W/1 1/4" NPT X 3/4" NPT FLUID
 END, CARBOX. NITRILE CUPS, SST
 DISC VALVE ASSEMBLIES

DRAWN	SJK	03-17-00	SCALE: NONE
CKD.	BKM	03-20-00	SIZE
APPD.	RMc	03-28-00	D P510904

E0413-HD Liquid End

ITEM	NO. REQD	PART NO.	PART NAME
①	1	P510889	POWER END: HEAVY DUTY
②	1	5260309	FLUID CYLINDER GROUP:
③	1	5273638	ATTACHING GROUP:
④	2	5273629	CYLINDER GROUP:
⑤	4	5257807	CUP: 1 $\frac{5}{8}$ " DIA, CARBOXILATED NITRILE FABRIC
⑥	1	5266225	LIT KIT:
* ⑦	1	5256139	FLUID CYLINDER: NITRIDED
* ⑧	8	5260142	VALVE SEAT: 450 SST
* ⑨	8	1219610	CAGE: 302 SST
* ⑩	8	5253499	DISC & SPRING ASSEMBLY: 450 SST
* ⑪	4	1219614	VALVE COVER:
* ⑫	12	1177394	O-RING: 1 $\frac{3}{16}$ " OD X $\frac{1}{8}$ " NOM., BUNA-N
* ⑬	2	1255887	VALVE COVER CLAMP:
* ⑭	2	1100064	HEX HD CAP SCREW: $\frac{1}{2}$ -13 X 1 $\frac{1}{2}$ " LG.
* ⑮	1	1109987	PLUG: $\frac{1}{4}$ " PIPE (NOT SHOWN)
** ⑯	4	1279148	UMBRELLA: BLACK
** ⑰	4	1269388	UMBRELLA WASHER:
** ⑱	4	1101339	O-RING: 1 $\frac{1}{16}$ " OD X $\frac{1}{16}$ " NOM., BUNA-N
** ⑲	1	1177200	CAPLUG: INT. 12
** ⑳	1	1177202	CAPLUG: INT. 17S
** ㉑	4	1101262	HEX HD CAP SCREW: $\frac{3}{8}$ -16 X 5" LG.
*** ㉒	8	A91684	CYLINDER GASKET:
*** ㉓	4	1241364	CERAMIC CYLINDER:
*** ㉔	4	1282557	PACKING HOLDER:
*** ㉕	4	5257986	PACKING WASHER:
*** ㉖	4	1284516	HEX HD CAP SCREW: $\frac{5}{16}$ -18 X 1 $\frac{1}{2}$ " LG.

NOTES:

△ B 1 TORQUE ITEM 21 TO 55 FT-LBS; ITEM 14 TO 35 FT-LBS
ITEM 26 TO 10 FT-LBS

2 TEST AT 500 RPM, 1500 PSI

△ B 3 RETORQUE ITEM 21 AFTER TEST

4 STAMP NAMEPLATE WITH THE FOLLOWING DATA:

MODEL NO. - E0413 HD PART NO. - P510904

MAX RPM. - 700 POWER - 14.6 HP / 10.9 KW

FLOW - 15 GPM/56 LPM MAX PRESSURE - 1500 PSI/10340 KPA

SERIAL NO. -

5 PAINT PER ENGR SPEC CP-20

E04 - HD Power End

ITEM	NO. REQD	PART NO.	PART NAME
	4	126098	CONN ROD BUSHING <i>(Must be Reamed)</i>
①	1	1273545	POWER FRAME:
②	1	1280633	MOUNTING BASE:
③	3	1104444	BALL BEARING: SINGLE
④	1	1104508	BALL BEARING: DOUBLE
⑤	4	P509546	CONNECTING ROD:
⑥	1	1101305	PLUG: 1/4" PIPE
⑦	4	1101095	OIL SEAL:
⑧	1	1273559	GASKET:
⑨	8	P510431	ROD BEARING:
⑩	4	1118553	RETAINER RING:
⑪	4	1219650	WRIST PIN:
⑫	12	1100068	HEX HD CAP SCREW: 3/8-16 x 3/4" LG
⑬	4	1216823	CROSSHEAD:
⑭	1	5277981	NAMEPLATE: (NS)
⑮	2	1187413	SELF-TAPPING SCREW: #4 x 3/16" LG (NS)
⑯	2	1105060	PLUG: 3/4" PIPE
⑰	4	1218743	SLEEVE:
⑱	1	1187577	KEY: 1/4" SQUARE, 1 3/4" LG
⑲	12	1177455	SPRING WASHER: 3/8
⑳	1	P510882	CRANKSHAFT: HD, DRIVE
㉑	1	P509560	CRANKSHAFT: HD, DRIVEN

B